



DOMINION 560 (A)

DOMINION 700 (B)



ESPECIFICACIONES TÉCNICAS

560 700

Potencia (Min-Max) (W)	240	330
Alimentación (V)	230	
Caudal (m3/h)	560	700
Nivel Sonoro (db)	48	
Filtro Entrada/Salida	G4	
Eficiencia Térmica(%)	90	88
By Pass Automático (%)	100	
Control Remoto	Digital	
Sensores	Temperatura y Humedad	
Clasificación Energética	A+	

VMC Doble Flujo

Instalación: Vertical

DIMENSIONES

A PESO: 70Kg

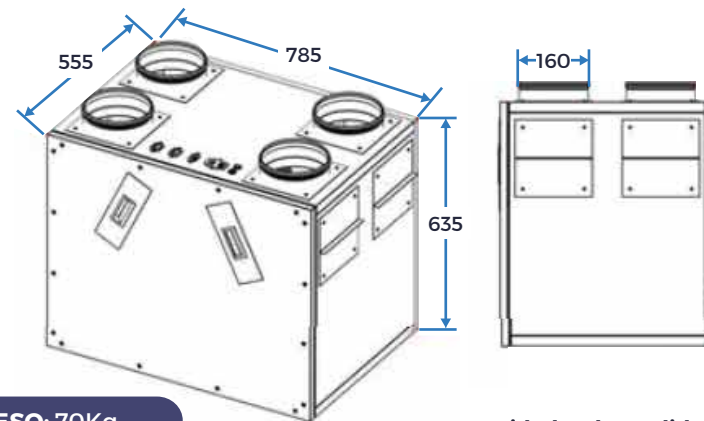

Controla toda la información desde el display digital (Incluido)

B PESO: 70Kg

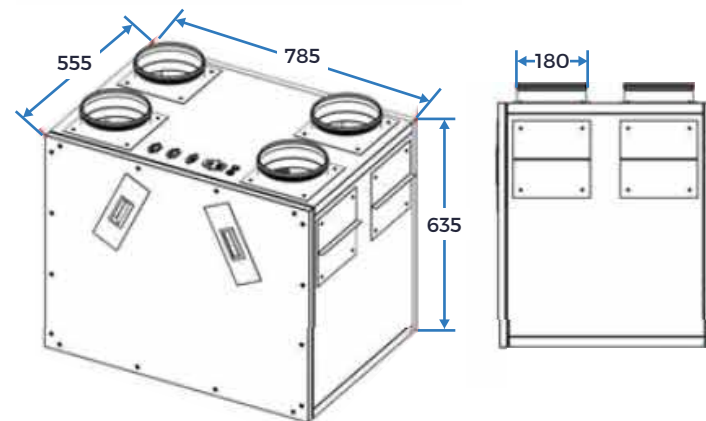

Unidades de medida: en mm

CARACTERÍSTICAS EMBALAJE

Tamaño Caja

Tamaño Palet

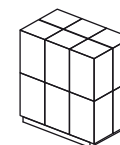

(A) 570x800x650mm

(A) 4

(B) 570x800x650mm

(B) 4

