

DOMINION 560 (A)



DOMINION 700 (B)



Control all the information from digital display (included)

TECHNICAL SPECIFICATIONS

	560	700
Power Max. (W)	240	330
Power Supply (V)	230	
Air Flow (m ³ /h)	560	700
Noise (db)	48	
Input / Output Filter	G4	
Thermal Efficiency (%)	90	88
Automatic By Pass (%)	100	
Digital Panel	Digital	
Sensors	Temperature and Humidity	
Energy Classification	A+	

Double Flow Heat Recovery Ventilation

Installation: Vertical

DIMENSIONS

A WEIGHT: 70Kg

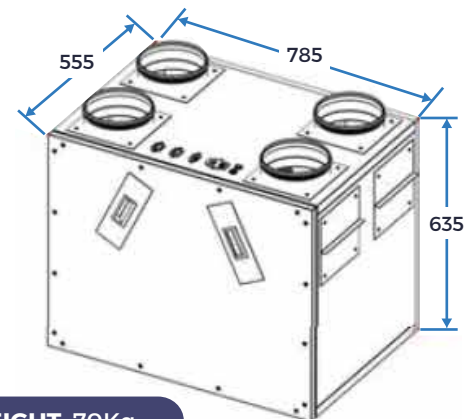

B WEIGHT: 70Kg

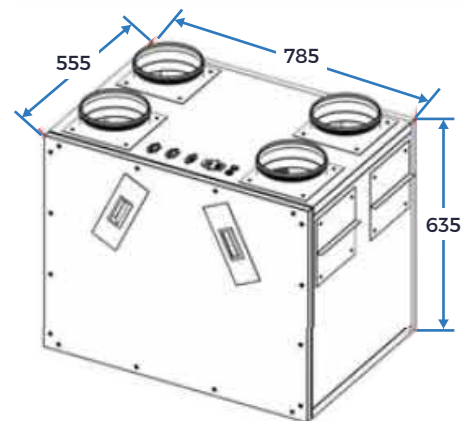

MEASUREMENT UNITS: mm

PACKAGING FEATURES

Box Sizes



(A) 570x800x650mm

(B) 570x800x650mm

Palet Sizes

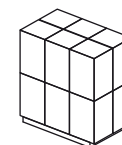

(A) 4

(B) 4

