



COMPACT 280
VM0280-SC/E



ESPECIFICACIONES TÉCNICAS

Potencia (Min-Max) (W)	12-56
Alimentación (V)	230
Caudal (m ³ /h)	260
Nivel Sonoro (db)	46
Filtro Entrada / Salida	F7
Eficiencia Térmica (%)	80
Amperaje (A)	<2

VMC Doble Flujo Intercambiador de placas de flujo cruzado

Instalación: Horizontal o Vertical



Mando regulador velocidad
On/Off Compact 280

Ref. VMR2003-SC
(No incluido)

DIMENSIONES

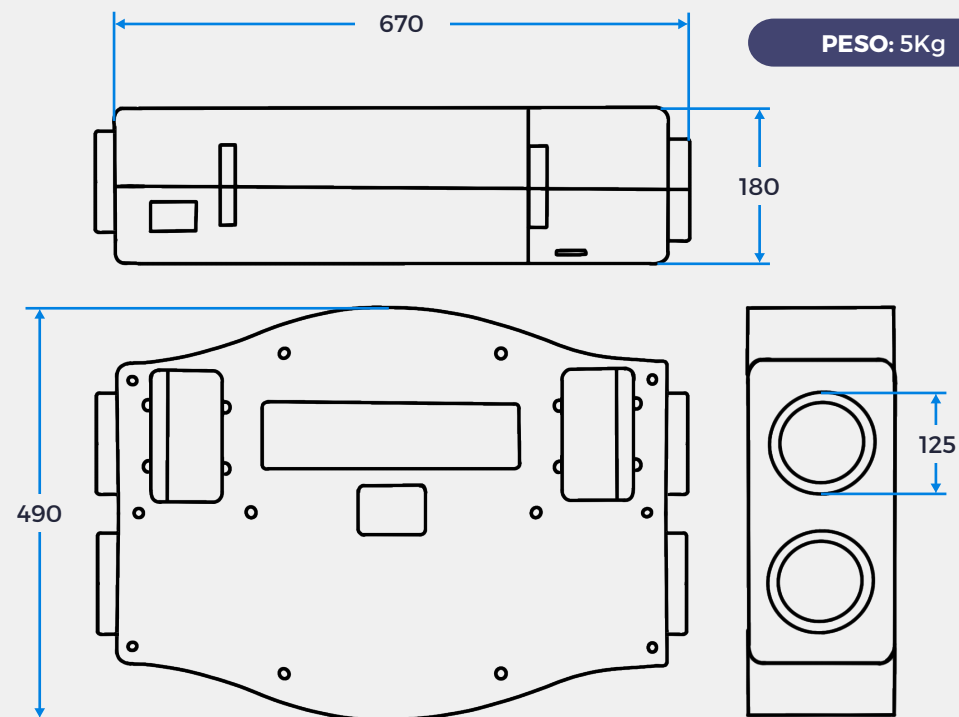

UNIDADES DE MEDIDA: en mm

CARACTERÍSTICAS EMBALAJE

Tamaño Caja



80x50x20cm

Tamaño Palet

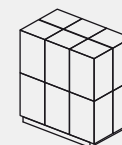

80x120cm
(24uds)

