



COMPACT 280
VM0280-SC/E



TECHNICAL SPECIFICATIONS

Power (Min-Max) (W)	12-56
Power Supply (V)	230
Air Flow (m ³ /h)	260
Noise (db)	46
Input / Output Filter	F7
Thermal Efficiency (%)	80
Amperage (A)	<2

Double Flow Heat Recovery Ventilation

Installation: Horizontal or Vertical



On/Off speed regulator knob
Compact 280

Ref. VMR2003-SC
(No included)

DIMENSIONS

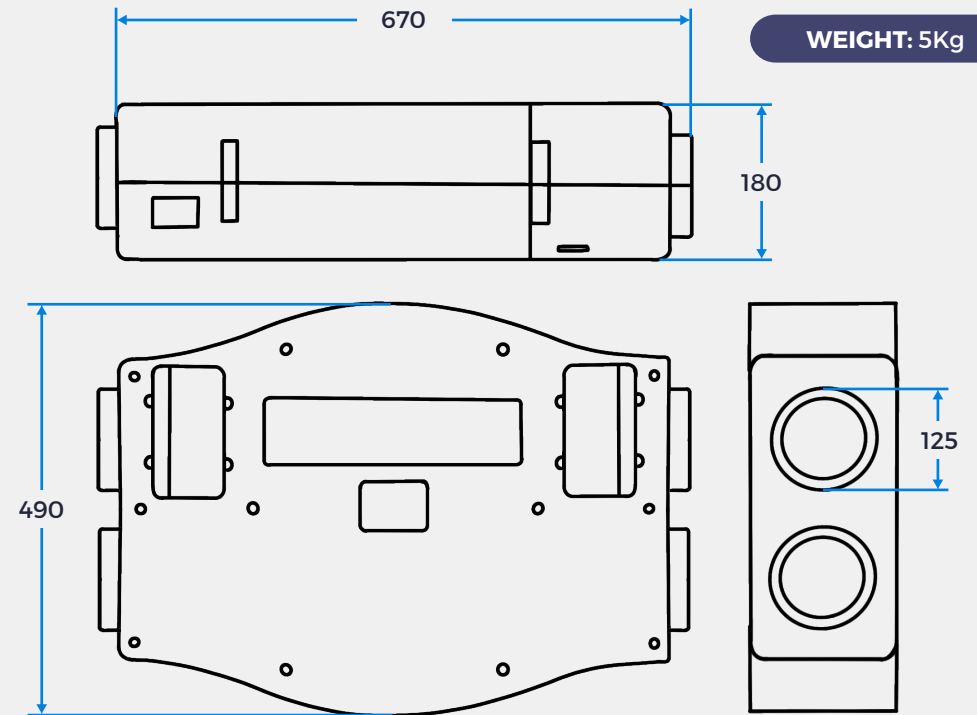

MEASUREMENT UNITS: mm

PACKAGING FEATURES

Box Sizes



80x50x20cm

Palet Sizes

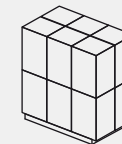

80x120cm
(24uds)

