



BREEZE 60



TECHNICAL SPECIFICATIONS

Power (Min-Max) (W)	1.2-6.3
Power Supply (V)	230
Air Flow (m ³ /h)	15-60
Noise (db)	28-48
Input / Output Filter	G3
Thermal Efficiency (%)	90
Sensors	Temperature and Humidity
Remote Control	Si

Double Flow Heat Recovery Ventilation

Installation: Horizontal or Vertical

DIMENSIONS

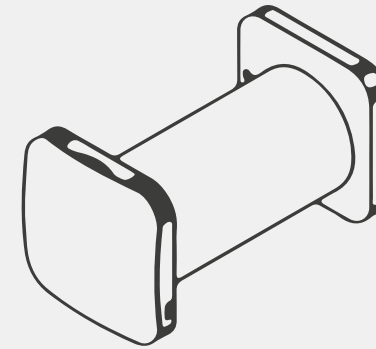

WEIGHT: 1Kg

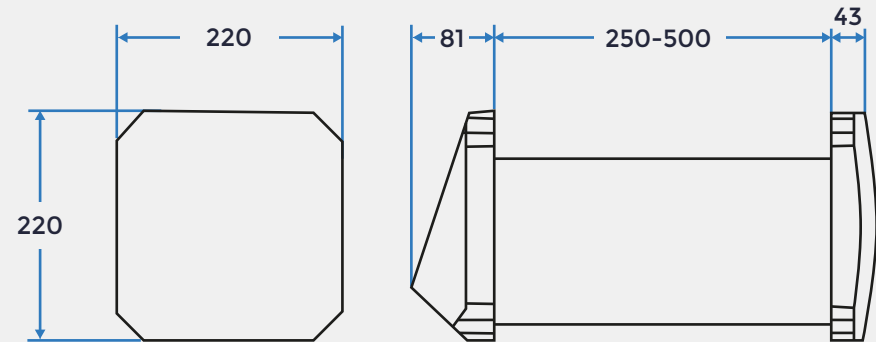

MEASUREMENT UNITS: mm

PACKAGING FEATURES

Box Sizes



250x250x400mm

Palet Sizes

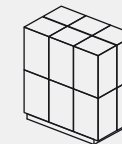

48

