

USER GUIDE

DOMINION 560-700

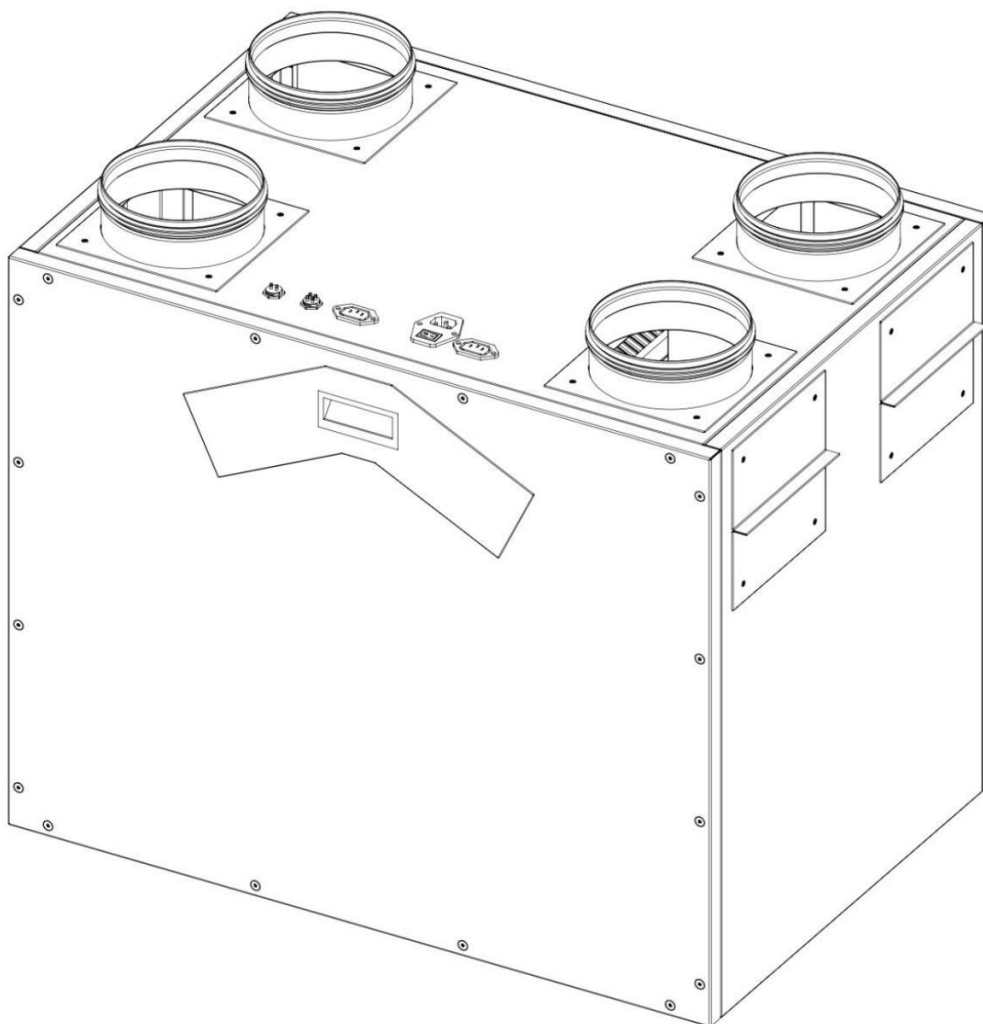

SACH HEAT RECOVERY UNIT MONTAGE, SERVICE AND USAGE MANUAL



DOMINION 560/700

PREFACE

Thank you for choosing the SACH Heat Recovery Units. The purpose of this document is to inform the users of the SACH Heat Recovery Unit about the parts and features of the device, to give information about operation and maintenance.

SACH heat recovery unit ensures high indoor air quality and energy savings at the same time. Heat transfer between the fresh air and the exhaust air is achieved by means of a plastic plate, counter-flow heat exchanger. It ensures high performance and high thermal conductivity, and efficient heat transfer between warm and cold air. The devices are designed to be easy to assemble, use and maintain. They work quietly thanks to the low noise self-motorized fans and noise isolation inside the device. Extensive controls, and accessory options give users the ability to custom fit their needs perfectly.

WARRANTY DETAILS

SACH guarantees that the heat recovery units it produced are of good quality. It ensures repair and exchange during the warranty period for faults which could manifest from structural weld flaws, material defects, or manufacturing problems as well as fans, damper system or electronics. SACH does not accept any liability for damage caused by improper and irresponsible use conditions.

Failings related to all mechanical and electrical components such as fans, motors, and circuitry, caused by defective modules or incorrect assembly are covered by warranty for 2 years, starting from the date of invoice to the customer.

If repairs or modifications to parts have been made without the written permission of SACH or the authorized service, the device will not be covered by the warranty. Repaired device malfunctions, and changed defective parts handled by means of the technical staff appointed by SACH or an authorized service will not void the warranty. Also the replacement of the G4 / F7 cassette filters contained in the device, made by SACH, will be excluded from this scope.

SACH warranty includes the replacement spare parts for fans, damper motor and system, and electronic components. It does not include the wages of service personnel, operation and / or maintenance costs. If the defect is within the coverage of the warranty, all transportation and exchange costs of the device and the technical staff appointment shall be borne by the authorized service, otherwise these costs must be met by the customer.

INDEX

DOMINION 560/700'S PARTS	5
1. BODY.....	6
2. AIR CONNECTIONS.....	6
2A. ALTERNATIVE SPIGOT LOCATIONS.....	7
3. ELECTRICAL CONNECTIONS.....	8
A. Boost Port.....	8
• Boost Mode.....	8
B. Com Input.....	9
C. Electric / Water heater.....	9
D. Power Input.....	10
E. Pre-heater.....	11
• Defrost Mode.....	11
4. SERVICE COVER.....	12
4A. MAGNETIC FILTER COVER.....	13
5. CASSETTE FILTERS.....	13
6. HEAT EXCHANGER.....	14
7. FANS.....	14
8. AUTOMATIC BYPASS DAMPER.....	16
• Free-cooling Mode.....	16
9. CONTROLLER CARD BOX.....	17
10.HUMIDITY SENSOR.....	18
11.DRAINAGE.....	19
12.WALL MOUNT.....	19
GENERAL WARNINGS.....	21

DOMINION 560/700's PARTS

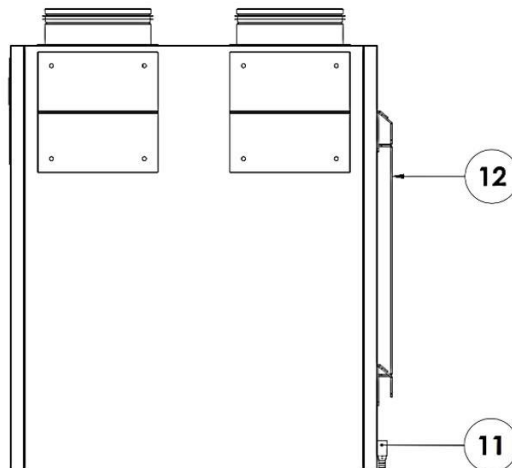
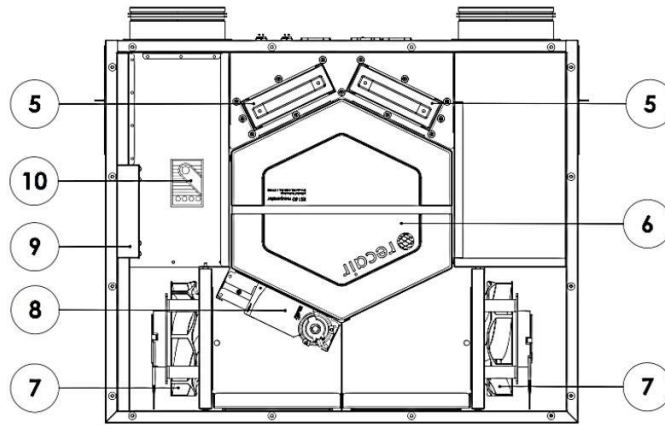
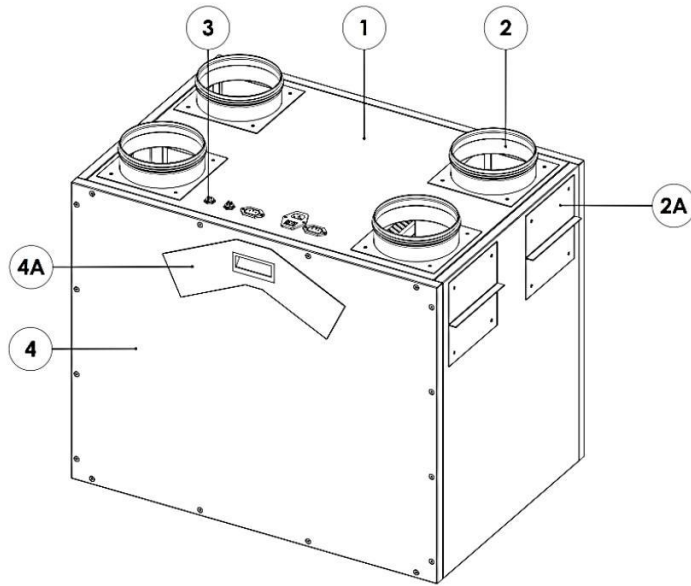

1. Body

The body of the DOMINION 560/700 heat recovery unit is made of galvanized sheet metal.

Inside of the metal frame is covered with acoustic insulation to reduce the noise levels. The inner surfaces of the device are smooth and have no sharp edges. The device is designed to minimize pressure losses.

2. Air Connections

All air connection spigots of the device are made of sheet metal and have a round cross-section. The duct connectors are sealed with double lipped rubber joints.

All air connections should be made with a metal duct with a diameter of $\varnothing 160$ mm for DOMINION 560 and $\varnothing 180$ for DOMINION 700.

The device needs 4 air connections. These are indicated on the device near air connection spigots with stickers. Please refer to these stickers when connecting the pipes;



Supply Air

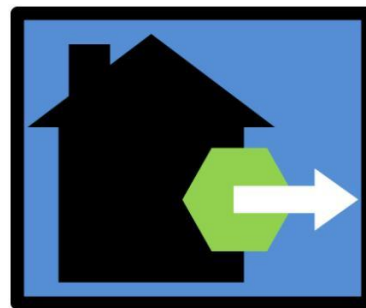

Exhaust Air



Extract Air



Fresh Air

Fresh Air: Gets the fresh air from outside of the house into the device.

Supply Air: Gives the heated fresh air to the inside of the house.

Extract Air: Gets warm air from inside of the house into the device.

Exhaust Air: Deposits the used, cooled air to the outside of the house.

2A. Alternative Spigot Locations

DOMINION 560/700 have alternative, empty spigot positions to be able to customize the positioning of the air duct connections to best fit your existing ventilation system. You can arrange them in vertical, horizontal or mixed variations.

1. To change the position of them, unscrew all the bolts with an M5 Allen wrench. There are 4 screws holding each spigot and duct cover.

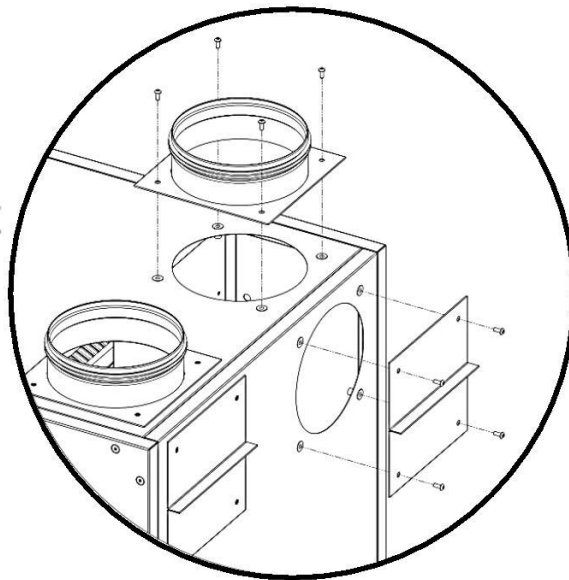
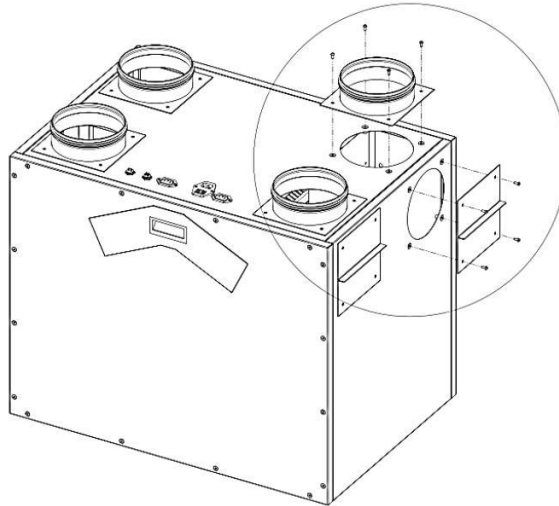

2. After changing the positions, screw them back tightly.

Do not put 2 duct covers or 2 spigots on the same corner. The device needs all 4 separate air ducts to operate and blocking an opening will cause damage to the device.

3. Electrical Connections

DOMINION 560/700 is designed to be plug and play, all the electrical connections are made with sockets for this purpose. Stickers on the device indicate what the ports are used for.

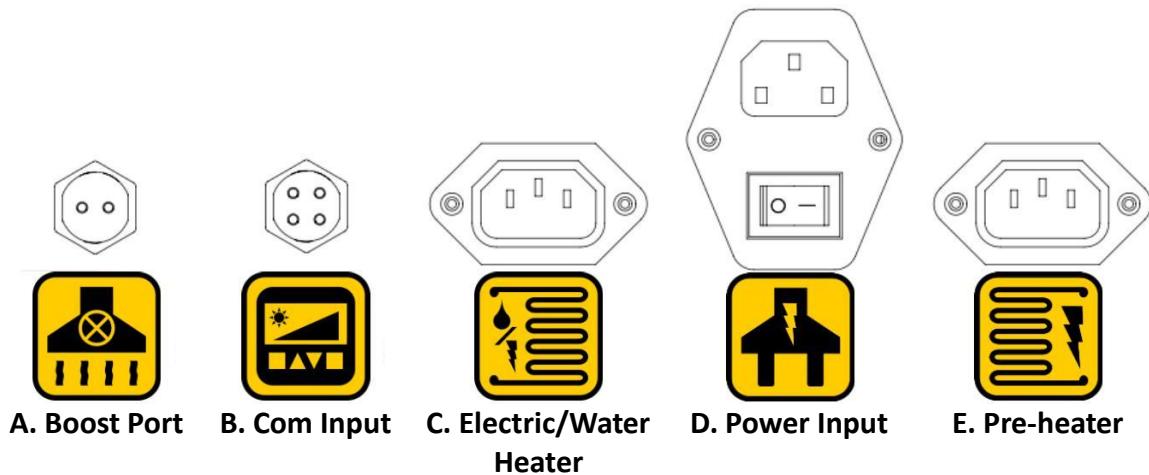

A. Boost port

The device can be connected to a kitchen aspirator via the boost port. This connection signals the device when the kitchen aspirator is turned on and it enters Boost Mode.

To connect, wire the 2 inner cables of the connector cable (sold separately) to the aspirators 220 - 240V and ground lines form its on-off switch. Boost port is bipolar, so the cable orientation is not important as long as one of them is power and the other is ground.

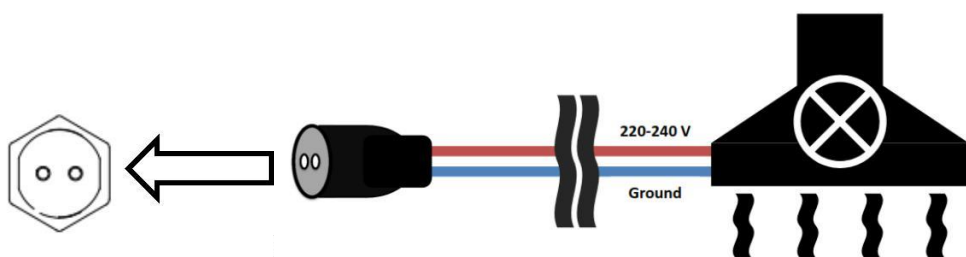

The socket is indicated by the respective label stickers shown on page 8.

Boost mode

Boost mode slows down the ventilator fan and runs the aspirator fan at maximum to ensure fast dissipation of air over a short time. This will increase

the air going out, thus reducing the smoke, fumes, odor and/or humidity of the house quickly.

Boost mode can be activated automatically by the built-in hygrometer, triggered by a set level of humidity, semi-automatically via the boost port if an external aspirator is connected to the boost port and turned on, and manually through the digital control panel.

B. Com input

The unit can either have a digital control panel. “Com input” port is used to connect the control panel to the device.



Digital Control Panel

Use the ON/OFF switch on the manual control panel to open and close the device. Turn the fan level knob to set both the aspirator and ventilator fan to a desired level. And get notified of a full filter when the filter LED lights up.

More information on how to use the digital control panel can be found in Digital Control Panel Manual.

C. Electric / water heater (Optional)

An electric or water heater can be added to the device, after the supply air duct, to further heat the air going inside to the house.

The heater must be installed at least two diameter distances away from the duct connection of the heat recovery unit.

There is an electrical valve on the hot water inlet of the water heater which is used to control the hot water flow into the coil. The cable from this valve should be connected to the “water/electrical heater port” of the device.

Water heater's pipe heads are threaded with M22 male threads, use respecting female thread connectors to connect the heater to the existing hot water system.

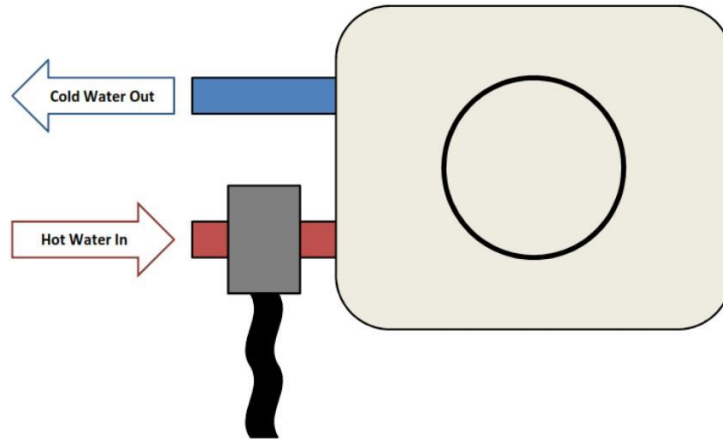

To connect the electric/water heater, plug the heater's power cord (if electric heater) or the power cord of the valve (if it is water heater) to the socket on the device.

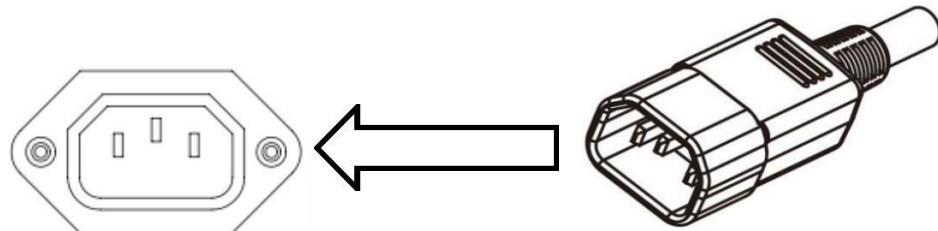

The socket is indicated by the respective label stickers shown on page 8.

To turn on the heater press MODE/OK on the digital controller until HTR is selected (flashing). Then press ▲ to turn on or ▼ to turn off the heater.

D. Power input

This is the main power source of the device. The socket is equipped with an on / off switch and have a 250V glass fuse. "I" is the **ON** and "O" is the **OFF** position.

The switch must be on **OFF** position before all the connections to the device is made.

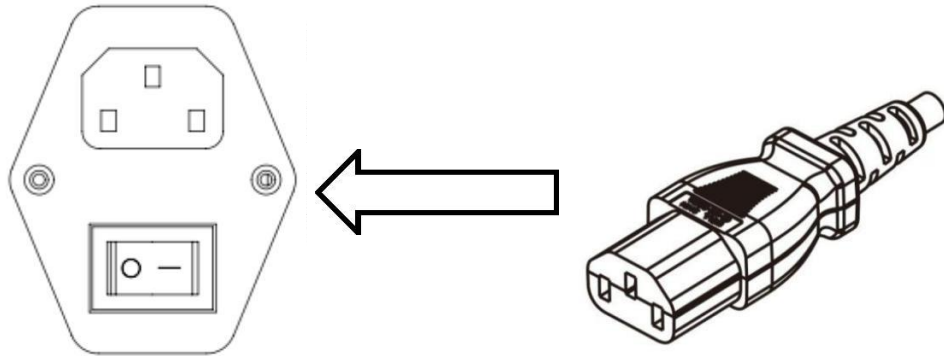

The socket is indicated by the respective label stickers shown on page 8.

E. Pre-heater (Optional)

In cold climates, where weather conditions are often drop below 0°C , it is recommended to use an electrical pre-heater before the fresh air intake to heat up the air, in order to protect the device from frost formation.

Pre-heater will activate automatically if the fresh air intake temperature drops below -3°C and this set temperature cannot be changed.

The heater must be installed at least two diameter distances away from the duct connection of the heat recovery unit.

To connect the pre-heater, plug the pre-heater's power cord to the corresponding socket on the device.

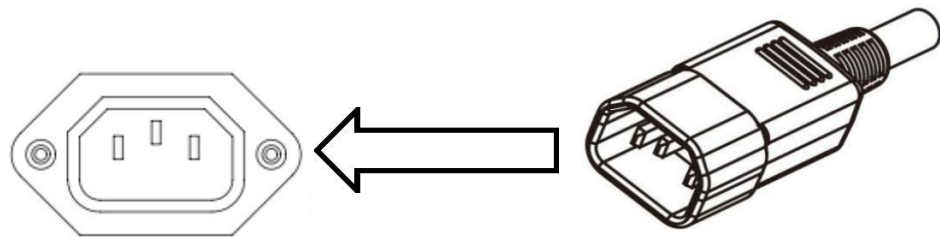

The socket is indicated by the respective label stickers shown on page 8.

Defrost Mode

If the outside temperature drops below -3°C , the device will enter defrost mode to prevent ice forming on the inside of the device. The device will enter defrost mode even if there is no preheater equipped.

Defrost mode will periodically adjust the fan levels to increase the inside temperature of the device, so that potential frost formed inside the device can melt.

Defrost mode sets the aspirator fan to maximum while decreasing the ventilator fan to stage 2. This mode will activate 5 minutes for every 1 hour.

4. Service cover

The unit has a service door that can be opened and sealed by screws for maintenance and replacement.

1. To open the cover, unscrew all the bolts (total of 16) shown below, with an M5 Allen wrench, and take off the cover.

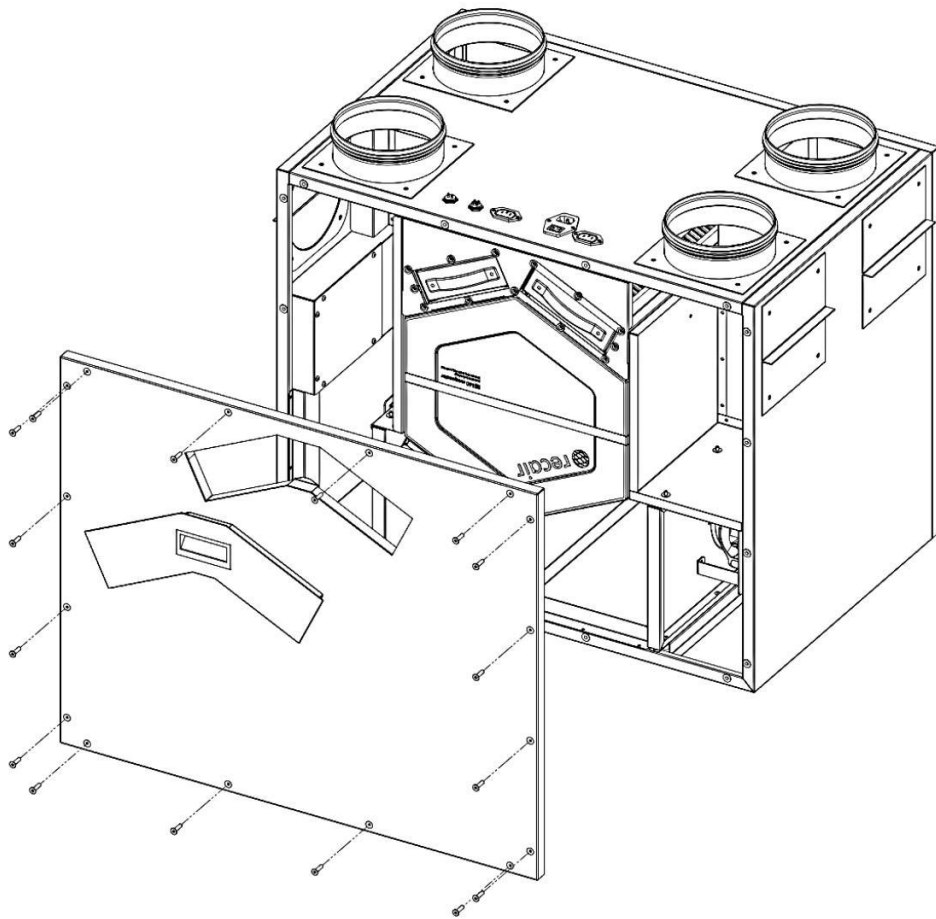

2. When closing the cover, tightly screw back the bolts.

4A. Magnetic Filter Cover

DOMINION 560/700 has a magnetic filter cover over the service door which can be easily removed to access the filters without completely removing the service cover.

5. Cassette filters

There are 2 filters after both the fresh air and the extract air ports which clean the air going into the device to protect the heat exchanger and other commodities from dust and abrasive particles.

Filter full status indicators for various control options are;

- Digital control panel: “Filter Full” warning can be seen on the screen. The alarm is timer based. When pressed OK, the filter warning will be turned off.

Changing the Filters

1. To remove the filters, open the filter cover. Since it is magnetic, just pull it from its handle.

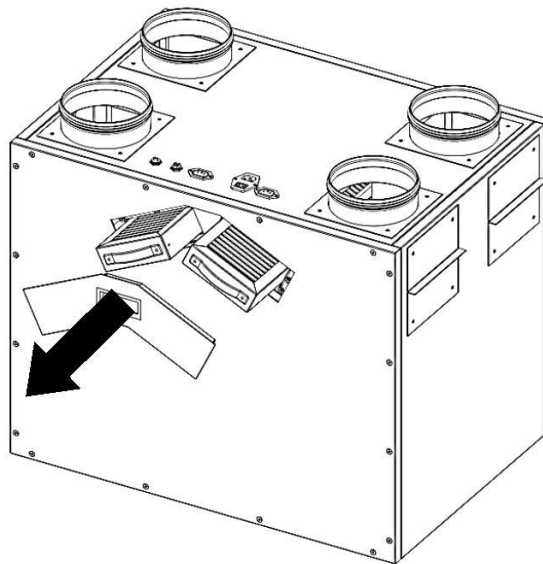

2. Pull the filters from their slots.
3. Put the new filters back in to the slot.
4. Close the magnetic filter cover back.

6. Heat exchanger

Plastic plated, high efficiency, hexagonal counter flow heat exchangers were used for the DOMINION 560/700.

Changing the Heat Exchanger

1. To remove the heat exchanger, open the service cover as explained in page 12
2. Pull the heat exchanger from its slot.

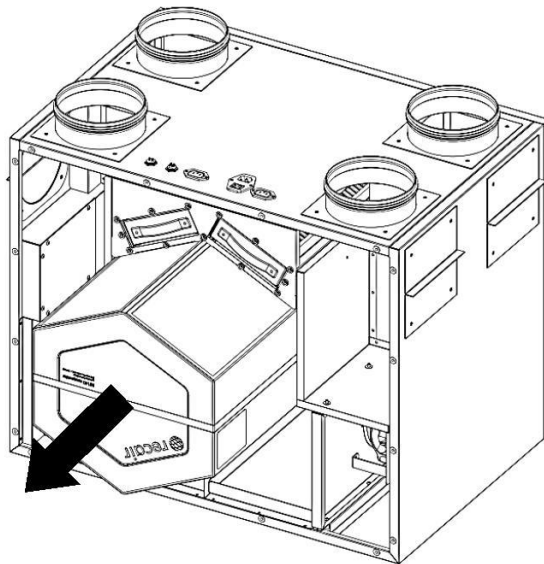

3. Put the new heat exchanger back in the slot.
4. Close the service cover and tighten the bolts.

7. Fans

All devices utilize self-motorized, silent, monophonic (220 V) and speed controlled fans.

To change the speed of the fans on the manual control panel, turn the fan speed knob to a desired level. Both of the fans will work at the same rate.

For digital control panel, press MODE/OK on the main screen to select ASP or VNT (aspirator and ventilator fans respectively). Then press ▲ to increase or ▼ to decrease the fan speed. For more information refer to the digital control panel guide.

Changing the Fans

1. To remove the fans, open the service cover first.
2. Disconnect the cables from its socket, noting the color and orientation of them.
3. Unfasten the screws holding it in place with an M5 Allen wrench. There are 4 screws on the top and 4 on the bottom of the fans.

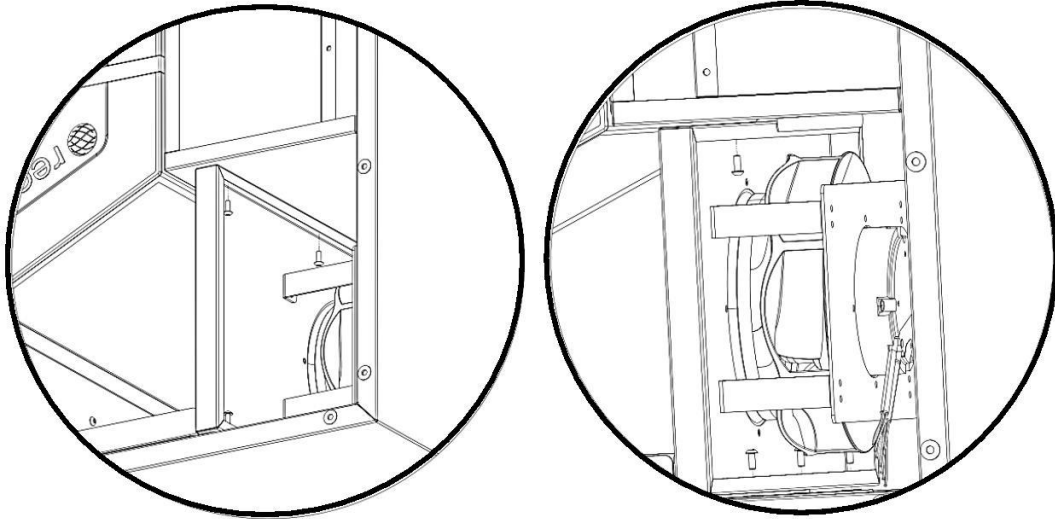

4. Pull the fan from its slot.

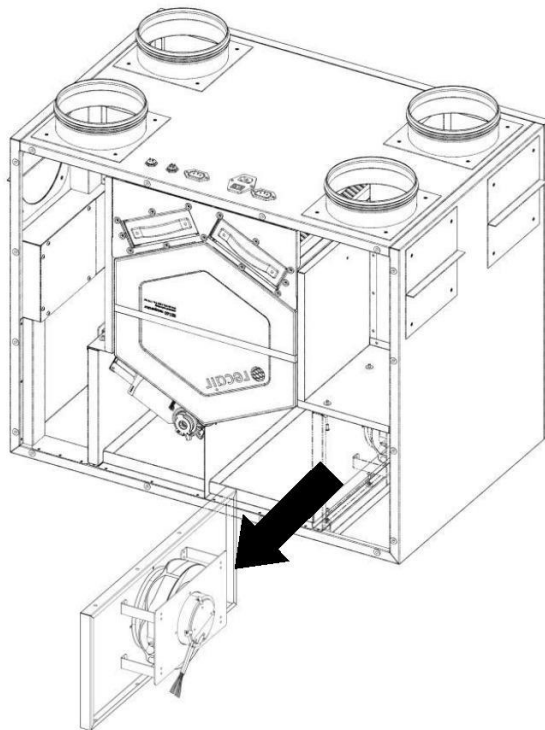

5. Put the new damper back into the slot.
6. Reconnect the electrical socket with the correct orientation.
7. Close the service cover and tighten the bolts.

8. Automatic Bypass Damper

At the back of the device, inside, there is a canal which bypasses the heat exchanger. Bypass damper opens or closes this canal along with the heat exchanger. (When the canal is closed heat exchanger is open and vice versa). Automatic bypass damper control allows this canal to be opened and closed accordingly.

Free-cooling mode

During summer and usually on seasonal transitions temperature inside a house will be warmer than the pleasantly cool outside air. For situations like that, heat recovery from the inside air is not always necessary. In this case free cooling mode is activated and the air flow is directed from the heat exchanger to the bypass canal. This will decrease the pressure drop and the load on the fans so the device can work with less energy, decreasing the power consumption of the device.

This set temperature is 23°C by default for manual control panel and it cannot be changed.

How to change the set temperature for digital control panel is explained on page 7 of the digital control panel manual.

Changing the Bypass Damper

1. To remove the bypass damper, open the service cover first.
2. Disconnect the cables from its socket, noting the color and orientation of them.
3. Unfasten the screws holding it in place with an M5 Allen wrench. There are 2 screws on the left – top and 4 on the right - bottom

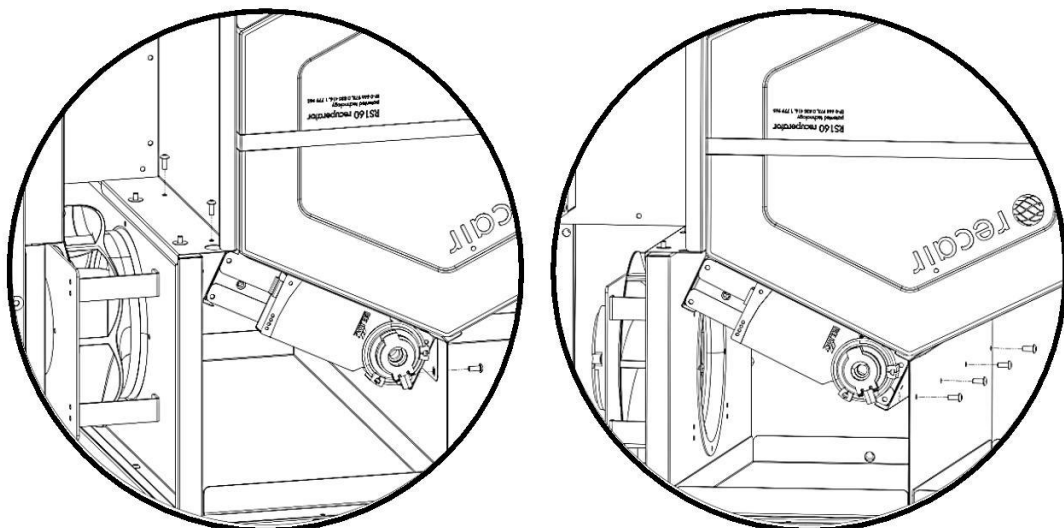

4. Pull the damper from its slot.

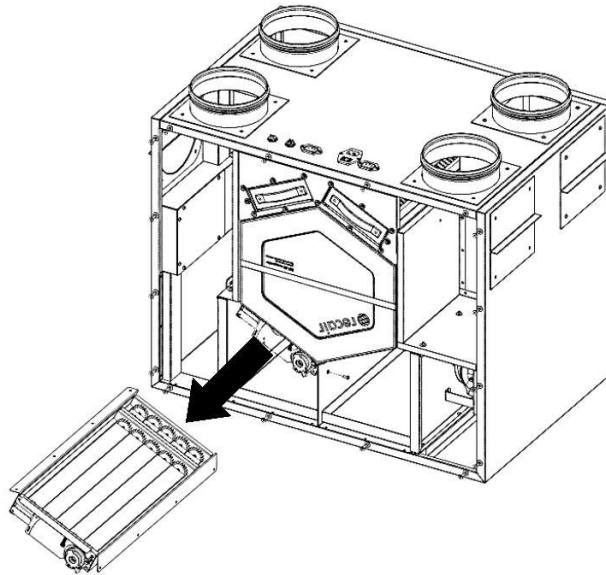

5. After removing the damper, put the new damper back into the slot.
6. Reconnect the socket with the correct orientation.
7. Insert the cable mess back under the metal cover.
8. Close the service cover and tighten the bolts.

9. Controller card box

All devices have a box on the body which encloses the electronic control card and electric wiring.

Changing the Electronic Control Card

1. To remove the controller card, open the service cover first.
2. Remove the heat exchanger from the device.
3. Unscrew the controller card box with an M5 Allen wrench to access the controller card.

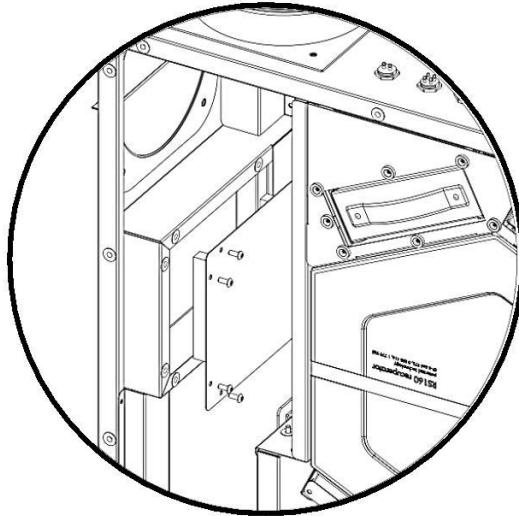

4. Disconnect the cables and wires, making note of the colors and orientation of the cables.
5. Reconnect the wires to the new card with the correct orientation.
6. Screw back the new card to its place.
7. Insert the heat exchanger back.
8. Close the service door and screw the bolts tightly.

10. Humidity sensor

The devices have a hygrometer located near the extract air duct. This sensor allows the device to switch to boost mode if the humidity level of the extract air goes above a certain level. When the humidity drops below the threshold level, the device stops boost and continues to operate as normal.

The default factory setting for the sensor is 70% relative humidity. If desired, the set humidity level can be changed manually to allow the device to switch to boost mode at a different humidity threshold.

Below is a drawing of the hygrometer, to change the boost mode trigger humidity level, turn the knob on the top, indicated with an arrow, to a preferred level of relative humidity.

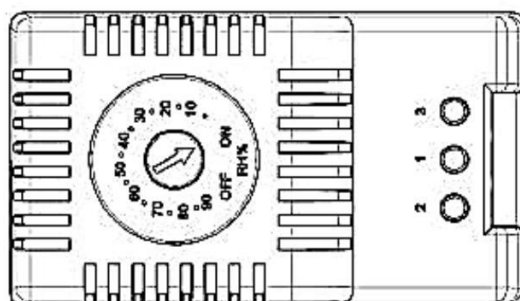

Changing the Hygrometer

1. To remove the hygrometer, open the service cover first.
2. Disconnect the cables on the hygrometer, and make note of the orientation of the cables.
3. Then push down onto the hygrometer to make it loose from its slot.
4. Put the new hygrometer by inserting it to the slot and push it until a “click” is heard.
5. Reconnect the wires with the correct orientation.
6. Close the service door and screw the bolts tightly.

11.Drainage

There is a collector tray made of galvanized sheet metal, to collect the condensing water droplets which can be formed inside the device. The drainage pipe has been taken out to be able to connect to the waste water system.

The drainage pipes must be connected to the waste water line before the device is started. The connection is made with a $\varnothing 19$ mm pipe.

The drain must never be led to the gutter, because this can cause water damage when it freezes outside

The connection of the drain must always have a water lock to prevent smells from the waste water line.



12.Wall Mount

You can use DOMINION 560/700 on the floor or you can mount it on the wall.

If you want to hang it on the wall, you must use its wall mount part. You can see the mount support part and montage details in the drawing below.

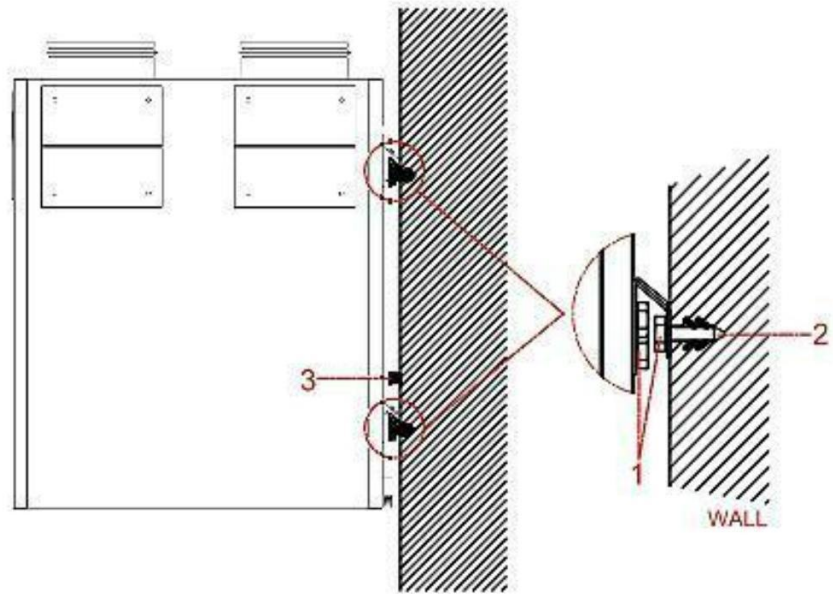

1. Screw
2. Screw anchor
3. Vibration chock

GENERAL WARNINGS

- Installation and commissioning of the device must be done by qualified personnel.
- The heat recovery device should not be disassembled in any case. Only authorized service personnel can disassemble and repair. Otherwise, electric shocks or injuries may result.
- All protective materials (stretch, etc.) placed on the device to prevent damage during transportation must be removed before the device is switched on. These materials can be inside or outside of the device.



-
- This appliance is not to be used in heated swimming pools, cold storage rooms, environments where humidity and heat are very different. It is not used in environments exposed to rain. (Otherwise, you may be exposed to electric shocks, and your device will not operate correctly.)
 - Do not use this device in corrosive environments such as acids and in corrosive environments. (oil mist, paint, toxic gases etc ...) Do not use the device in flammable media (containing explosive gas).
 - These devices operate at 230V - 50 Hz.



-
- The fixing of the device should be done well and securely.
 - Do not apply force to electrical connections and control box while lifting the device.
 - Connect waste water lines to the pipes of the drain pans.
 - When connecting the device, be careful of the service spaces, otherwise the filter changes and the device cannot be interfere with the fan motors.
 - The drain pipes must be connected to the waste water lines before the device is started.
 - If the control panel displays a warning about filter, you should clean or change your filter.
 - Check that the drain line is properly installed.
 - The fresh air inlet (exterior part) of the device with exhaust should be such that it does not miss the rainwater into the appliance.
 - This device should be used in a temperature range of -10 ° C to +40 ° C, where the relative humidity is below 60%. It is recommended to use an electric heater when the appliance is to be humidified at the fresh air intake. Failure to get fresh air into the



desired properties can lead to a reduction in the amount of oxygen in the room and discomfort. In such cases, the indoor air quality sensor can be placed on the suction side.

- Apparatus (switch, fuse, cable etc.) to be used with the system must be selected from the staff with the quality certificate and the high strength.
- Make sure that the power supply of the device is suitable for the power supply with the appropriate cable and thermally protected switch.
- Make sure that the device is not in electrical contact with air ducts and building steel constructions. Otherwise, electrical leaks and fire may occur.
- A circuit breaker working with the fuse and switch system must be placed on the mains connection to the device.
- Electric heaters must be used with the heat recovery device automatic controller. In the automatic controller, the small relay contacts for controlling the resistances are of low amperage capacity and are intended for dry contact (open / close). It is necessary to check the contactors to operate the resistances to be controlled by this contact. (A separate panel should be made for the electric heater and the contactor, switch, fuse must be installed.)
- Switch off the electrical connections before interfering with the appliance.
- Make sure the fan motor is not running before opening the service doors. Do not open the service lid while the fan is running. Before removing the fan during service, unplug the power cord and remove it from the power outlet.
- There should not be foreign substances in the cell.
- Clean the G4 filters and heat exchanger with compressed air. Do not clean with flammable gases or water.
- Clean G4 filters with compressed air at least every 45 days depending on ambient conditions. After cleaning five times, replace filters with new ones.
- During installation of the devices to the duct system; sharp turns in the canal system, sudden contraction or expansion in multiple canvases and canal diameters should not be allowed.

Sachvac.com

Calle Vereda de los Barros 67
Pol. Ind. Ventorro del Cano
28925 - Alcorcón, Madrid
Spain



+ 34 91 633 34 93
+34 635 41 49 80



@sachvacuum



@sachvacuum



@sachvacuum



@sachvac



Air to breathe